



NEW CERTIFIED  
IP66 CONTROL  
UNIT

# PMD2 Plus/EZHD

## ELLIPTIC, MULTI-ZONE AND HEAVY DUTY ENHANCED METAL DETECTOR

### KEY FEATURES

- Superior Detection and Throughput
- Compliant with and certified to the applicable Standards for Enhanced Metal Detectors
- New mechanical structure with high protection degree
- Aesthetic, Compact and Light Weight
- Unmatched Reliability
- Rapid Installation: no tools required for assembly



TOOLS FREE  
ASSEMBLY

PORTABLE  
CONFIGURATION  
AVAILABLE



GSA Contract Holder



[www.ceia-usa.com](http://www.ceia-usa.com)



THREAT DETECTION THROUGH ELECTROMAGNETICS

Strict requirements and detection needs call for security checkpoints to perform efficiently even under very challenging conditions.

The **PMD2 Plus/EZHD detects firearms and knives**, even when they are **hidden within body cavities**, and accurately indicate the position of the threat, its intensity and its prevalent composition.

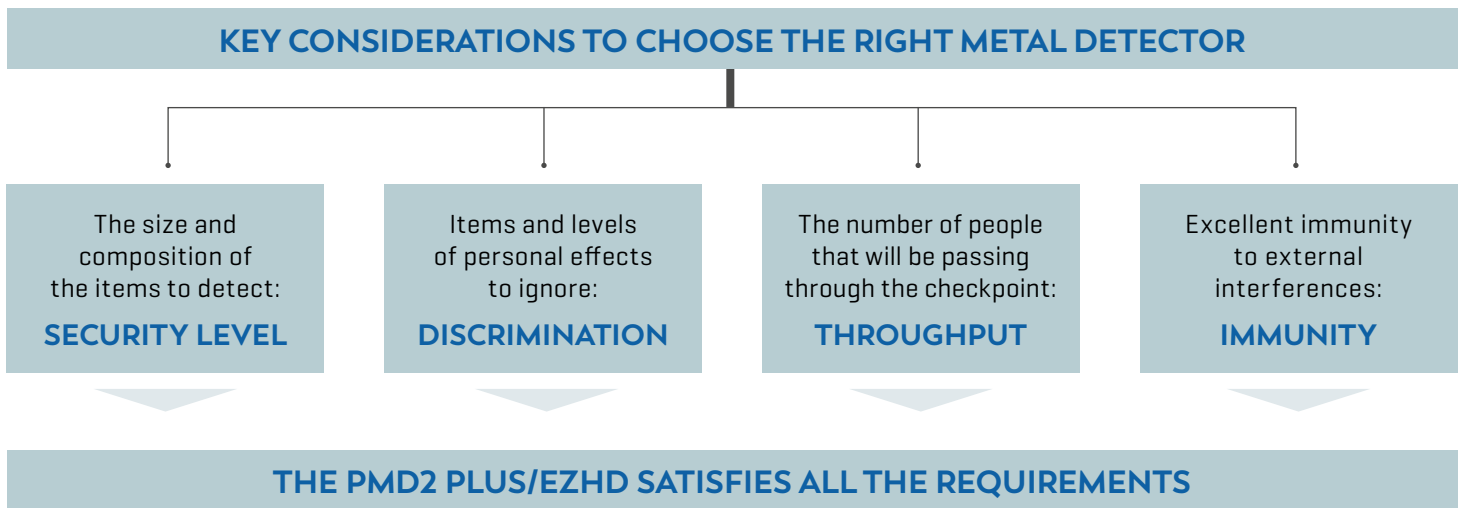

### MOST POWERFUL AND VERSATILE SECURITY FEATURES

- Up to 50 built-in Security Programs
  - ▶ Up to 30 International Standards
  - ▶ Up to 20 Customizable Levels

**Setting the Security Levels could not be easier and more versatile than in the PMD2 Plus/EZHD.**

Users can choose directly from the known International Standards or request implementation of a Standard personalized to their own requirements. Users can also create their own program and save it in internal memory for later use.

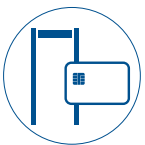

- Chip Card system for fast, simple and secure parameter changes (i.e. alarm volume and tone, counter reading, etc.) and security level selection.
- Any security standard can be enhanced with selectable random alarm probability

### CHIP CARD SYSTEM

The system allows Security Management to **set the Security Level quickly, reliably** and without having to program the device in any way.



The **PMD2 Plus/EZHD** has a very low nuisance alarm rate even at the strictest Security Standards requested today, and therefore allows high transit flow rates and the minimum need for intervention by inspection personnel.



### DETECTION OF ALL METALLIC THREAT ITEMS

- Capability to detect the full range of metal weapon threats even within body cavities
- Quick, accurate analysis of all parts of the body of people in transit, from the shoe level to the crossbar
- Guaranteed coverage for all orientations and locations, never in need of calibration
- Met-Identity technology for Identification of Threat Composition



### HIGH DISCRIMINATION & THROUGHPUT

- Cutting-edge discrimination technology allows personal effects to be ignored, creating rapid transit flow
- No need to remove items such as belts, coins, keys, jewelry, watches, wallets, etc.
- Better Discrimination = Shorter Lines and Less Staffing



### IMMUNITY TO EXTERNAL INTERFERENCES

- Certified Exceptional immunity to environmental interferences makes the Metal Detector easy to use even when electrical noise is encountered

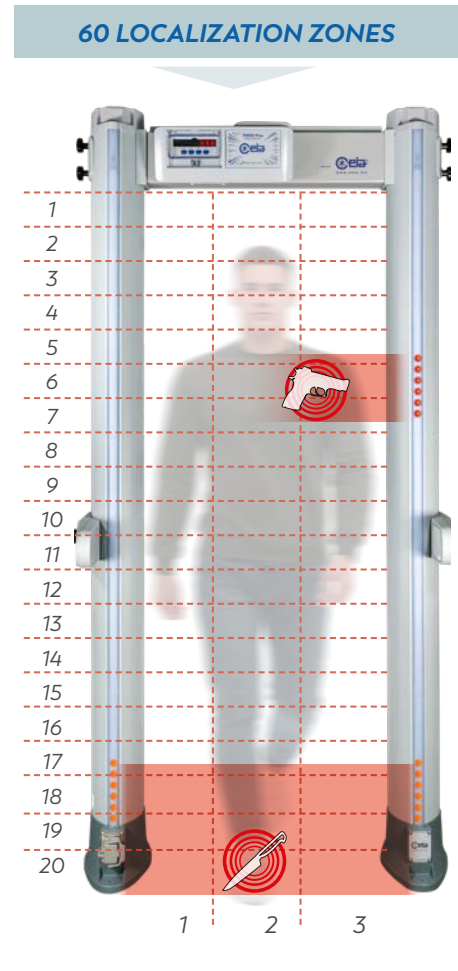

### 60 PINPOINTING ZONES

(20 vertical x 3 lateral) with left, center and right indication.



### NEW CERTIFIED IP66 CONTROL UNIT ENCLOSURE

- Total compatibility with previous control units
- Robust, antivandalic structure through the use of high-performance polymers for the construction of housing
- Waterproof / Dustproof: IP66 compliant (IEC 60529)
- Exceptional impact resistance at low and high temperatures and resistance to corrosion from atmospheric agents
- Display made with specific polymer to improve the visibility of the LEDs by increasing the definition and clarity



### UNIQUE ALARM SIGNALING

- High visibility of the control unit and of the zone indication, independent from the operator position and the installation environment
- Flexible Acoustic Alarm Signaling System:
  - ▶ 10 Continuous and Pulsed Tones
  - ▶ 34 Special Sounds
- 10 Alarm Volume Levels
- Very High Precision Transit Counter
  - ▶ In-Bound, Out-Bound transits
  - ▶ Alarm Rate calculation
  - ▶ Automatic Compensation for repeated transits of the same person



### RAPID INSTALLATION

- One touch guided automatic installation (OTS)
  - ▶ Innovative function assisting the installation through an automatic step-by-step procedure
- Continuous self diagnostics assures monitored performance reliability



**HEAVY DUTY CONFIGURATIONS** are suitable for **applications where the equipment is subject to frequent relocations**. These models are characterized by cables with metal, military grade, connectors for quick plugging/unplugging and a **rapid installation – all parts can be assembled without tools**.

## MODEL CONFIGURATION

MODEL	PMD2 Plus/EZHD	PMD2 Plus/EZHD-N	
	STANDARD VERSION	NAVY REDUCED HEIGHT VERSION	
Reduced height for low-ceiling applications	—	●	
4 display bars each programmable as zone indicators and/or pacing lights	●	●	
60 localization zones [20 vertical x 3 lateral] with left, center and right indication	●	●	
Specific Shoe Alarm color indication	●	●	
Antivandalic and Antitampering IP66 Control Unit	●	●	
Weatherproof gate compliant with IEC 60950-22	●	—	
Chip Card Reader	●	●	
BT, infrared and RS-232 communication	●	●	
Programmable Random Alarm capability*	●	●	
3-Level Password and hardware key access protection	●	●	
Met-Identity technology	●	●	
<b>OTS:</b> One Touch Automatic Self Installation	●	●	
<b>OFV:</b> Automatic Operational Functional Verification	●	●	
<b>AVS, EVA:</b> Automatic Vibration Compensation	●	●	
<b>CS:</b> Automatic Channel Search	●	●	
<b>FGA:</b> Automatic Floor Gain Adjustment	●	●	
<b>TFV:</b> Automatic Technical Functional Verification	●	●	
<b>ENA:</b> Automatic Environmental Noise Compensation	●	●	
Powered by safe low voltage DC	●	●	
Anti-tamper on/off switch	●	●	
High Precision Transit Counter [2-beam]	○	○	
Integrated web-server & logger [including USB and Ethernet interfaces]	○	—	● STANDARD
32.3" useful passage width	○	○	○ OPTION
Transport case	○	○	* Transit Counter required

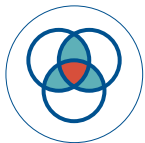

### COMMUNICATION CAPABILITIES

TYPE OF OPERATION	ETHERNET	USB	INFRARED	BT	RS-232
MAINTENANCE	○	○		●	●
REMOTE CONTROL	○		●	●	●
REMOTE DATA COLLECTION	○				

● STANDARD  
○ OPTION

## GENERAL DIMENSIONS

### PMD2 Plus/EZHD

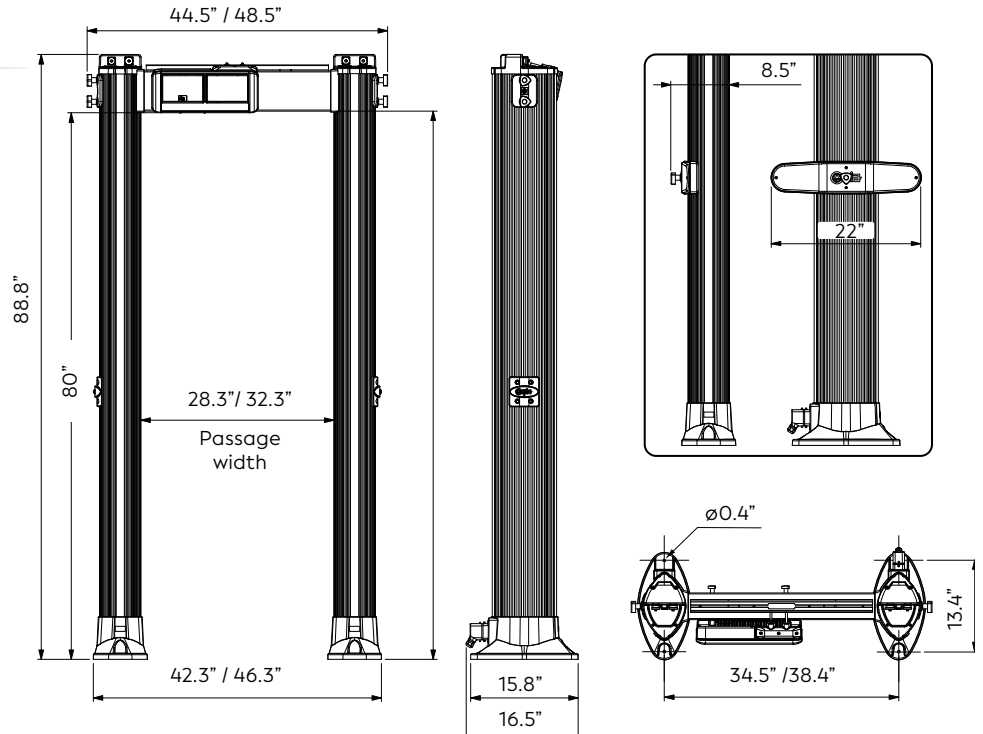

### PMD2 Plus/EZHD-N

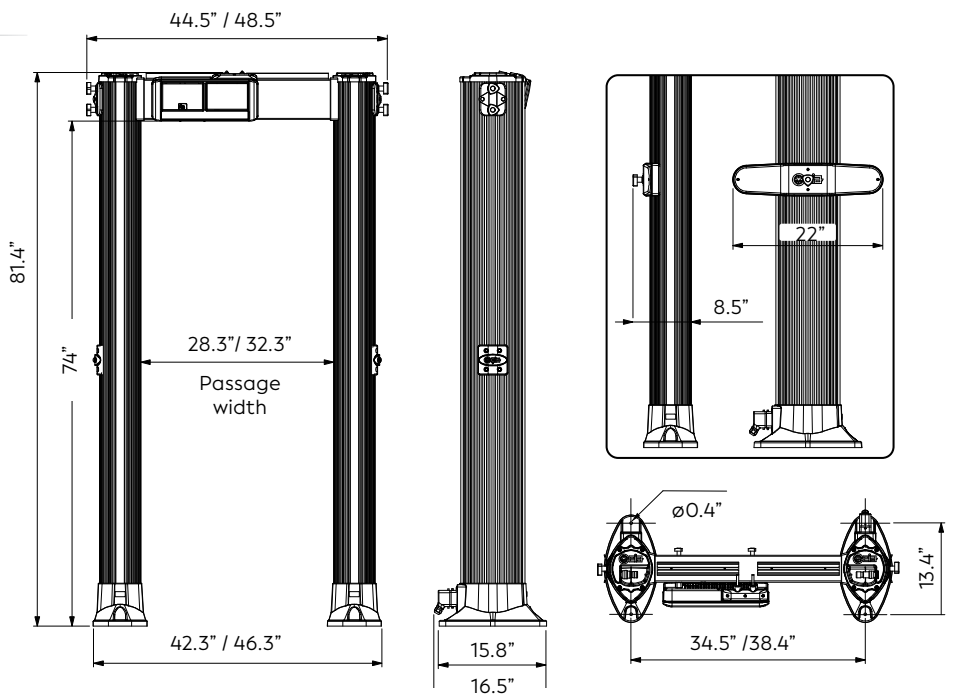

## OPTIONS / ACCESSORIES

### OPTIONS

#### INTEGRATED WEB-SERVER & LOGGER

Anti-tamper on/off switch, RS-232, USB, 10/100 baseT Ethernet interface, data logger, real-time clock, integrated web-server, statistical transit data analysis.

P/N APSIM2Plus/E

#### HIGH PRECISION TRANSIT COUNTER (2-BEAM)

Two photocells fitted into the archway allow counting of transits, alarms and percentage of alarms.

P/N 62928

#### TRANSPORT CASE

- Protects the metal detector during transport and storage
- Minimizes storage space
- Dimensions: 92" x 16.5" x 30"
- Weight [case only]: 132 lbs
- Standard version [P/N 57290]
- Navy reduced height version [P/N 64296]



#### CANVAS BAGS FOR TRANSPORT AND ASSEMBLY

P/N 93569

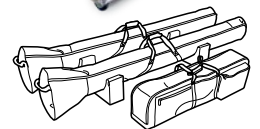

### ACCESSORIES

#### CHIP CARDS

Chip cards for simple and secure selection of Security Levels and parameter setting. List of chip-cards available on request.

#### MBSU-2-HD

Separate, compact long life power supply in stainless steel case and high protection degree [IP65], with embedded fast charger [P/N MBSU-2-HD]:

- 14h [typical continuous operation]
- 7h typical charging time



#### MD-SCOPE

Powerful, PC based installation and service Software. Includes oscilloscope and terminal functionality [P/N MD-SCOPE2].



#### RCU2

Control unit for full remote access, including alarm signalling and programming of CEIA Metal Detectors [P/N RCU2]



#### CROSSBAR BATTERY BACK-UP

Typical operating time in battery mode is 7 hours.

- 28.3" passage width [P/N 95360]
- 32.3" passage width [P/N 94628]



#### IRC-1

Infrared Remote Controller for wireless remote programming of the control unit [P/N 47180]



#### ELLIPTIC GATE PROTECTIVE COVER

Protective Cover is designed to protect the gate in permanent outdoor installations during periods of inactivity from water, ultraviolet rays, humidity, dirt, sand, temperature spikes and other environmental hazards. The Protective Cover is column-fitted, durable and weatherproof.

The cover is simple to install and to remove.

- 1 P/N 64395
- 2 REF. 76520 [with photocells]

[www.ceia.net/security/EllipticGateProtectiveCover.aspx?lan=us1](http://www.ceia.net/security/EllipticGateProtectiveCover.aspx?lan=us1)



#### STABILIZING PLATES

Comfortable alternative to direct floor mounting for uneven floor and mobile applications:

- 1 Metal plates [P/N 64355]
- 2 Anti-tilting metal plates [P/N 70914]
- 3 Canvas bags for transport [P/N 94934]



#### UPPER TIE-DOWN POINTS

P/N 64886



#### CEILING POWER ADAPTER

P/N 63732



#### TEST SAMPLES KIT

Reference Samples for accurate verification of the Security Level. Includes guided procedures and certificate of calibration.

P/N EMD-SK-GAL - P/N EMD-SK-GDML



## SPECIFICATIONS

<b>GATE STRUCTURE</b>	State-of-the-art, robust and washable compact elliptical columns Protected against aging, weather and wear
<b>OPERATIONAL FEATURES</b>	High discrimination and transit flow rates five or more times greater than other metal detection systems Quick reset time as short as 0.2 seconds for high throughput rate Very high detection speed (up to 50" ft/sec.) Built-in operational functional verification One-touch key reading of inbound, outbound and Security Level Data
<b>QUALITY</b>	Continuous self diagnostic system Proven reliability No periodic re-calibration and preventive maintenance required No scheduled maintenance Fully digital design
<b>ALARM SIGNALING</b>	Multi-zone display bar for "height on person" localization 4 light bars with selectable entry/exit and pacing indication Green and red metering signals proportional to the mass of the detected target 10 selectable continuous and pulsed tone plus 34 special tones 10 selectable sound intensities ranging from 0 to 90 dbA at 3.3 ft
<b>TYPE OF SIGNALING</b>	Fixed or proportional to the mass in transit - visible from 19.7 ft under lighting of 4000lux 60 distinct zones [20 vertical x 3 lateral] entry and exit side
<b>PROGRAMMING</b>	Up to 50 built-in Security Programs Ethernet interface (option) Security level: International Standard [IS] command / Chip card Local by Control Unit alphanumeric display and keyboard Programming and chip card access protected by user and super-user passwords
<b>ENVIRONMENTAL DATA</b>	Power Supply : 100...277V~ ±10%, 47...63Hz, 40 VA typical consumption Operating temperature: -4°F to 149°F [-34°F to 158°F upon request] Storage temperature: -34°F to 158°F Relative humidity: 0 to 95% [without condensation]
<b>INSTALLATION DATA</b>	Automatic synchronization between two or more metal detectors with distance of down to 2" without the use of external cables Automatic Installation function [OTS]

### CERTIFICATION AND COMPLIANCE

- Compliant with and certified to the applicable Standards for Enhanced Metal Detectors [EMD]
- Compliant with the applicable electromagnetic Standards on Human Exposure and Pacemaker Safety
- Compliant with all Airport Security Standards worldwide
- Compliant with applicable International Standards for electrical safety and EMC

### APPLICATIONS

- ✓ GOVERNMENT BUILDINGS
- ✓ INDUSTRIES (SECURITY)
- ✓ NUCLEAR FACILITIES (SECURITY)
- ✓ PRISONS (VISITORS)
- ✓ PUBLIC EVENTS
- ✓ AMUSEMENT PARKS
- ✓ COURTS
- ✓ CRUISE SHIPS
- ✓ DATA PROCESSING CENTERS (EDP)
- ✓ HOTELS
- ✓ SCHOOLS SECURITY

### COMPREHENSIVE SUPPORT

**CEIA USA PROVIDES FULL OPERATIONAL AND TECHNICAL TRAINING SUPPORT BY CERTIFIED PERSONNEL EITHER AT CEIA FACILITY OR AT CUSTOMER LOCATION.**



**CEIA USA Ltd** - 6336 Hudson Crossing Parkway, Hudson OH 44236

**P** 330-405 3190 • **F** 330-405 3196 • **E** security@ceia-usa.com • **CALL** (833) 224-2342 (CEIA)

[www.ceia-usa.com](http://www.ceia-usa.com)

*CEIA USA reserves the right to make changes, at any moment and without notice, to the models (including programming), their accessories and options, to the prices and conditions of sale - DP060K0095v1000uUS - 2022*