



EMIS[®] series

TSA
QUALIFIED*

MEET ECAC
PERFORMANCE
STANDARD*

AUTOMATIC SCREENING FOR NON-METALLIC CARGO

KEY FEATURES

- Detect automatically detonators and metal components of explosive devices
- Low cost of ownership
- No dedicated operator
- High throughput
- No ionizing radiation
- Completely solid-state construction (no periodic maintenance or calibration required)

INSPECTION OF

- Flowers and perishable goods
- Paper products
- Textiles and Clothing
- Plastic and wooden products



* The **EMIS series** devices are the **only Cargo Metal Detection equipment** that are both endorsed by the **ECAC** and qualified by the **TSA**.



www.ceia.net/security/emis/

THREAT DETECTION THROUGH ELECTROMAGNETICS



The **CEIA EMIS (Electro-Magnetic Inspection Scanner)** equipment are security screening devices designed to inspect non-metallic cargo.

Using **CEIA exclusive Electromagnetic Profile Analysis technology**, these devices ensure automatic detection of detonators and electronic circuits from IEDs (Improvised Explosive Devices), ammunition and weapons composed of metal (knives, firearms). In case of detection, the scanners give an audible and visual alarm.

FULLY AUTOMATIC DETECTION

The EMIS is designed to automatically detect detonators and metal components of explosive devices inside paper, newspaper, perishable goods such as produce, fish and meat (fresh or frozen) and organic material in general.

Electromagnetic inspection is the most suitable and quickest method for checking non-metallic cargo. The advanced technology employed in the EMIS minimizes the interaction with the goods themselves and does not depend on visual interpretation of an image by an operator.

DIFFERENT SIZES FOR INSPECTION OF SINGLE PACKAGES OR ENTIRE PALLETES

- ✓ **EMIS 8075** FOR SCREENING OF PACKAGES
- ✓ **EMIS 130160 - EMIS 130200** FOR PALLETIZED CARGO
- ✓ **ALL MODELS** CAN BE USED AS A STAND ALONE OR IN-LINE INSPECTION DEVICE



EMIS 8075 FOR PACKAGE INSPECTION

OVERALL DIMENSIONS (mm)

EMIS 8075

- 1 TUNNEL USEFUL AREA: 800 mm x 750 mm
- 2 PROGRAMMING PANEL
- 3 OPTICAL AND ACOUSTIC ALARM
- 4 CONVEYOR BELT
- 5 MOTOR CONTROL UNIT
- 6 ENTRANCE

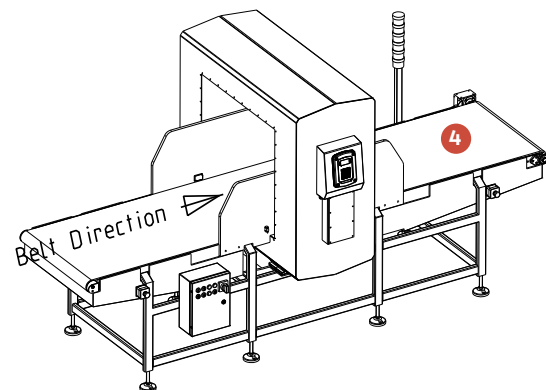
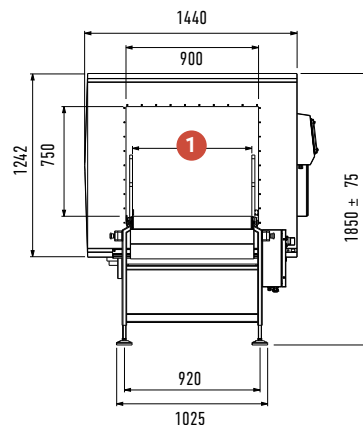
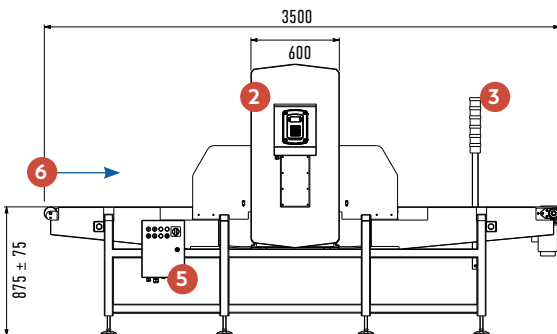

EMIS models 130160 and 130200 are the first available automatic e.m. scanners for inspection of entire pallets of non-metallic cargo. Moreover, the CEIA EMIS Series are the first e.m. scanners that have been **qualified according to the TSA Air Cargo Screening Program**.

They are also the first devices that have been tested under the ECAC Common Evaluation Process Framework and **meet the ECAC performance standard for Metal Detection Equipment (MDE)**.



EMIS 130160 AND 130200 FOR PALLETIZED CARGO

EFFICIENCY AND LOW COST OF OWNERSHIP

The EMIS offers the ability to automatically screen complete pallets, helping to avoid the need for breakdown and ensuring the highest throughputs are maintained when compared to other approved technologies.

The automatic electromagnetic analysis offers a superior level of detection performance guaranteeing the safety of all shipments.

The automated screening process does not require the use of an operator for image interpretation and no regular staff rotation periods for constant operation. Peak periods can be helped by the increased throughput EMIS offers, combined with the ability to redeploy staff normally associated with image interpretation to areas where they are most needed.

The solid-state construction requires no periodic maintenance or calibration ensuring a substantial reduction in the life-cycle costs of the equipment.

EMIS 130160 - 130200

- 1** TUNNEL USEFUL AREA:
1300 mm x 1700 mm (130160 model)
1300 mm x 2000 mm (130200 model)
- 2** PROGRAMMING PANEL
- 3** POWER SUPPLY AND MOTOR CONTROL UNIT
- 4** OPTICAL AND ACOUSTIC ALARM
- 5** ENTRY ROLLER CONVEYOR
- 6** ENTRY CONVEYOR STRUCTURE
- 7** EXIT CONVEYOR STRUCTURE
- 8** EXIT ROLLER CONVEYOR

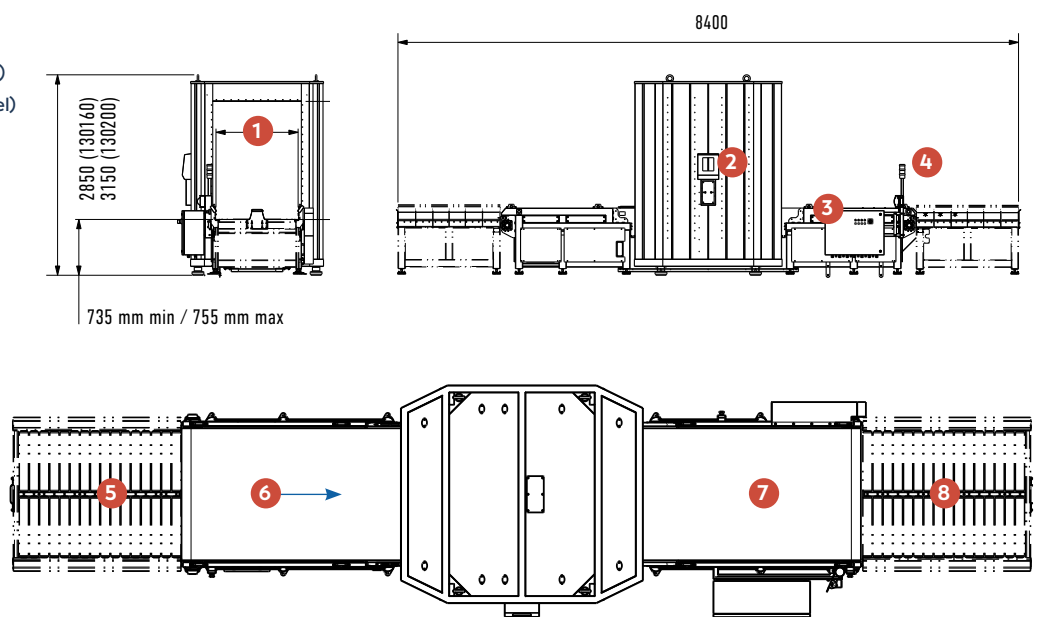

SPECIFICATIONS



DETECTION FUNCTIONS

Analysis of containers of perishable goods and paper without metal content

CEIA electromagnetic-profile analysis technology

0.5 ppm by weight Detection Sensitivity at maximum load (130160, 130200 models)

Tunnel useful area	8075 model: 800 mm x 750 mm	130160 model: 1300 mm x 1700 mm
		130200 model: 1300 mm x 2000 mm
Height of the conveyor belt	8075 model: 875 mm ± 75 mm adjustable	
	130160 - 130200 models: 735 mm min / 755 mm max	
Maximum Conveyor Load	8075 model: 180 Kg typical – 275 Kg evenly distributed	
	130160 - 130200 models: 1500 Kg	
Maximum pallets height	130160 model: 1650 mm - 130200 model: 1950 mm	
Speed/Inspection Time	30 m/min (8075 model)	
	Less than 1 min per pallet (130160 - 130200 models)	

STRUCTURE

Material	AISI 316L Stainless Steel	
Protection degree	IP65	
Weight	8075 model: 700 kg	130160 model: 5000 kg
		130200 model: 5150 kg

POWER SUPPLY

Supply voltage	200-240 V, 50-60 Hz	
Maximum current	11.4 A (8075 model) - 20 A (130160 - 130200 models)	

PROGRAMMING AND COMMUNICATIONS

Modern, rugged and user friendly interface	
Easy to read, high-contrast (3000:1) graphic display	
Rugged, anti-vandalism stainless steel keyboard	
Programming access protected by multiple password levels	
Selection of the operative program	
Programming type	Local, through the built-in keyboard
Memory	125 programs, 100000 storable events
USB Storage device connection	

ALARM FUNCTIONS

Automatic slowing and stopping of the conveyor	
Manual alarm reset and consequent restarting of the conveyor	
Visible and audible alarms	

CONTROL INPUTS

Connection of:	following conveyor authorization, emergency button	
Serial interface RS232	Built-in	
Bluetooth connection	Built-in (deactivable)	
USB Interface	Built-in	
Ethernet interface	Built-in 10 - 100 Base-T	
Video Camera	Built-in IP camera (130160 - 130200 models)	

OUTPUTS

5 programmable relays (30Vca – 2.5A) for the activation of external devices	Ready to load relay
	Ready relay
	Ejector relay
	Preceding conveyor relay
	Item clear relay

ENVIRONMENTAL DATA

- Operating temperature: -10°C to +50°C
- Storage temperature: -25°C to +70°C
- Relative humidity: 0 to 95% (without condensation)

CONFORMITY

- Conforms to the international standards currently applicable for electrical safety and EMC, and to the applicable EC Regulations
- Complies with Regulations relating to pacemakers, defibrillators or other vital support systems, pregnant women and magnetic storage media

APPLICABLE COMMODITY GROUPS

- Grains and animal feed, produce, perishables, bakery goods, dry goods
- Seafood and Meat
- Textiles and Clothing (without metallic accessories)
- Paper products, plastic, rubber
- Printed Material
- Flowers and herbs

FOR THE FOLLOWING CCSF

- Shipping facilities
- Freight Forwarding Facilities
- Third Party Logistics Providers
- Manufacturing Facilities
- Warehouses
- Distribution Centers
- Growers of produce



CEIA - Zona Industriale 54, 52041 Vicinaggio - Arezzo (ITALY)

T +39 0575 4181 • E infosecurity@ceia-spa.com

www.ceia.net/security/emis/



CEIA reserves the right to make changes, at any moment and without notice, to the models (including programming), their accessories and options, to the prices and conditions of sale. DP210K0004v7000hUK - 2023

