



## Power Cube® SA/80 series

Wideband Low-Medium Frequency  
**25, 50, 75, 100, 150, 200 kW** Green Generators

### Features / Benefits



- High power output
- High level of performance with minimal operating costs
- Automatic tracking & best optimization to load
- Constant, repeatable power generation via microprocessor control
- Minimum cooling water flow required
- High Safety: output insulation from the mains
- Highly integrated with a small footprint
- User Friendly Operations through graphical touch-screen interface
- Stainless Steel casing
- Compliant with Electrical Safety and Electromagnetic Compatibility Regulations



POWER CUBE 100-SA/80 GENERATOR



[www.ceia.net](http://www.ceia.net)





The SA/80 Generator Series is a high power induction unit in a very **compact size with embedded advanced microprocessor based control software and state-of-the-art electronics.**

This allows very high efficiencies (>96%) under a wide variety of workload conditions while maintaining precise, stable and repeatable output power.

## SA/80 Generators Series with 25, 50, 75, 100, 150 and 200 kW power

For more than 40 years CEIA has been manufacturing Inductive Heating Systems, achieving great experience in the field, and carrying out continuous R&D activities.

The **SA/80 Generators** and **Network Matching [Heating Head] hardware design** combined with a state-of-the-art power and control electronics allow an **extremely high conversion efficiency and therefore a high reliability and low operating costs.**

The embedded microprocessor control system is based on a wide feedback signals network, that allows a fine coil voltage and current control, and guarantees the consistency and accuracy of output power generation, suitable for highly repeatable production processes.

All the CEIA Generators are equipped with an isolation transformer that separates the coil output from the power supply line guaranteeing a high level of operator safety.

## Automatic Output Matching to Wide Load Impedance

**The SA/80 Generators adaption system to the load is fully automatic.** The operator does not have to carry out any type of mechanical operation on the Generator or on the Heating Head.

**This function selects the best Generator parameters,** maximizing conversion efficiency at each set point power. This reduces the set up time and associated costs. Furthermore, during operation, a continuous and real time automatic tracking of the output matching is carried out in order to always meet the set point power even in case of workload condition changing. [i.e. heating temperature over curie point]. This provides for the greatest possible efficiency during the entire heating cycle.

**The SA Series Generators are therefore ideal for industrial production processes,** where the maximum reliability, repeatability and output power accuracy are required together with wide load matching flexibility, fast set-up and low operation costs.

## Friendly Human Machine Interface

A wide 7" high-resolution touch screen panel allows the operator to access programming function parameters quickly. All the process parameters are continuously displayed on the Main screen:

- Coil Voltage
- Coil Current
- Output Power Setting and Real time Reading
- Temperature Setting and Real time Reading
- Cooling Water Temperature and Flow
- Working Cell [Recipe]
- Generator Status [Alarm]

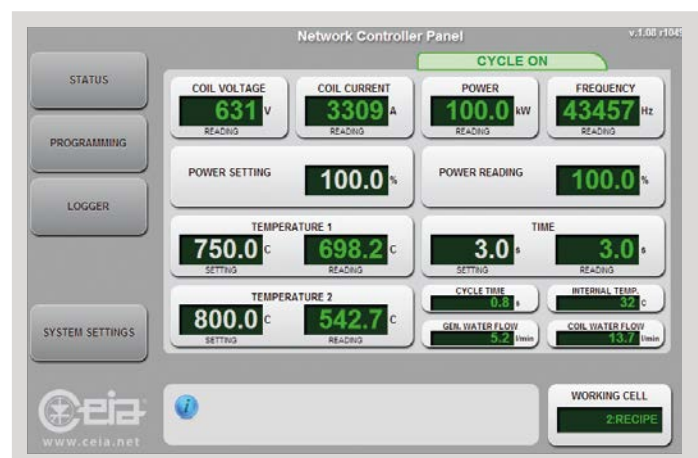

► MAIN SCREEN



### Integrated Web server and Data Log System

- Integrated Webserver with 2-port 100base-T Ethernet switch
- No client software required, only a web browser
- Zero configuration network for simple setup
- Built-in Rich Internet Application (RIA) for Status Monitoring, Remote Programming, Logging and Thermal Profile Management
- Internal storage capacity for more than 100,000,000 data samples

The SA/80 series is equipped with integrated Data Log and Web Server system. It is possible to perform automatic data storage, for a proper process quality control, monitoring heating temperatures, output power, frequency, voltage and inductor current. An Ethernet TCP/IP port allows access to the internal web server of the Generator for remote programming settings and interface with SCADA / DCS systems.

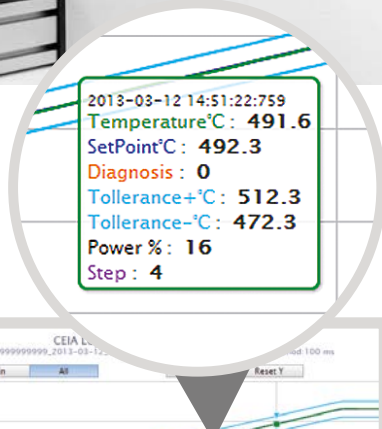

► DATA LOGGER SCREEN

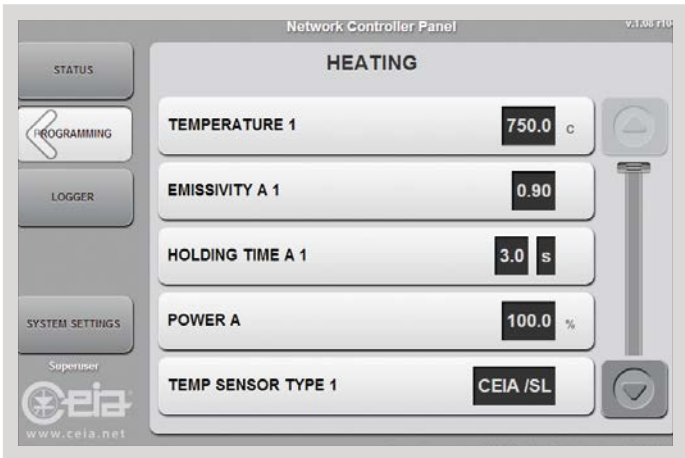

► HEATING MENU

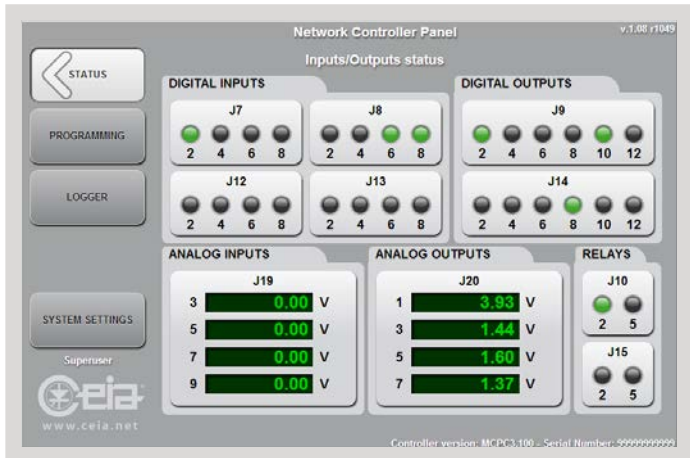

► INPUT/OUTPUT STATUS

Thanks to the **Thermal Profile Monitoring software**, coupled with the **SH/SLE Optical Pyrometers**, the user is now able to set specific temperature profiles, monitor and certify the heating process of each production item.

### Thermal Profile Management and Monitoring

- Up to 20 Programmable Temperature and Time Segments per Process
- Up to 100 different storable processes
- Maximum Power Output Programmable for Each Individual Segment
- Temperature Tolerance Window Programmable for Each Individual Segment
- Out-of Tolerance and End-of-Cycle Outputs for Each Process

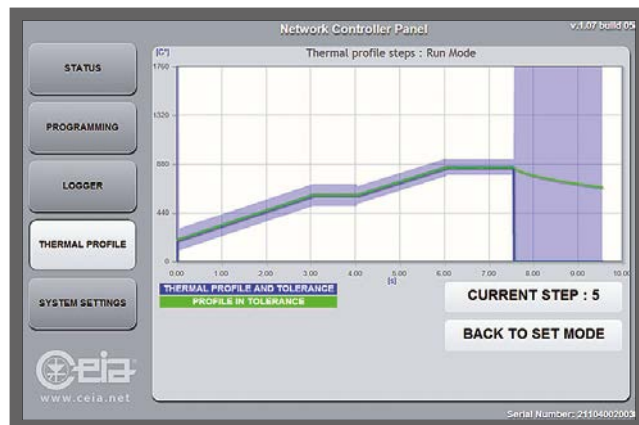

► *Real-time Thermal Profile screen, combined with Web server and Data Log option*

### Field Bus Management

- Management and control of the heating process via Field Bus protocol:
  - ▶ Profinet
  - ▶ EtherCAT
  - ▶ EtherNet / IP
  - ▶ Others upon request (DeviceNet, Profibus, CANopen, CC-Link, CompoNet, ControlNet, Modbus-RTU or TCP, SERCOS III)
- Field Bus and Network compliance certification available upon request



### Thermocamera Control

- Interface with Thermocamera via a direct Ethernet connection
- Management of up to two independent zones of interest (ROI # 1 and ROI # 2).
- Ideal for temperature control on large surfaces or in applications where the location of the hot spot moves during the heating process (Max Temperature Spot Automatic Tracking)
- Simultaneous measurement and control of two different areas used to prevent over heating

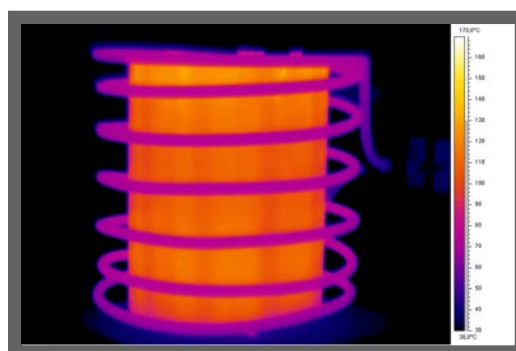

# Generators Specifications



		PW3-25-SA/80	PW3-50-SA/80	PW3-75-SA/80	PW3-100-SA/80	PW3-150-SA/80	PW3-200-SA/80
<b>POWER SUPPLY AND POWER</b>	Max. input power	25 kW	50 kW	75 kW	100 kW	150 kW	200 kW
	Max. power at inductor	2000 kVAR	3000 kVAR	4000 kVAR	5000 kVAR	5000 kVAR	10000 kVAR
	Power supply	400 Vac $\pm$ 10%, three-phase - 50 Hz / 60 Hz, no neutral					
	Input current	45A max	85A max	130A max	170A max	255A max	360A max
<b>FREQUENCY RANGE</b>		25 kHz... 100 kHz					
<b>COOLING</b>	Water cooling system	Direct off-take from mains at recommended pressure of approx. 4 bar (min. 2 bar, max. 6 bar)					
		Minimum flow rate: • Generator: 2,5 litres per minute. • Heating coil: 3 to 10 litres per minute, depending on the coil used.	Minimum flow rate: • Generator: 2,5 litres per minute. • Heating coil: 5 to 20 litres per minute, depending on the coil used.	Minimum flow rate: • Generator: 3 litres per minute. • Heating coil: 8 to 25 litres per minute, depending on the coil used.	Minimum flow rate: • Generator: 3 litres per minute. • Heating coil: 8 to 30 litres per minute, depending on the coil used.	Minimum flow rate: • Generator: 3 litres per minute. • Heating coil: 8 to 30 litres per minute, depending on the coil used.	Minimum flow rate: • Generator: 3 litres per minute. • Heating coil: 8 to 30 litres per minute, depending on the coil used.
		Water temperature at inlet: from ambient temperature to 45°C (non condensing)					
	Electric chiller system	Power: $\geq$ 5 kW Water flow rate: 0.3 $\div$ 0.8 m <sup>3</sup> /h Pressure: 3.5 bar - 5 bar	Power: $\geq$ 10 kW Water flow rate: 0.5 $\div$ 1.5 m <sup>3</sup> /h Pressure: 3.5 bar - 5 bar	Power: $\geq$ 15 kW Water flow rate: 0.7 $\div$ 1.7 m <sup>3</sup> /h Pressure: 3.5 bar - 5 bar	Power: $\geq$ 20 kW Water flow rate: 1.0 $\div$ 2.0 m <sup>3</sup> /h Pressure: 3.5 bar - 5 bar	Power: $\geq$ 30 kW Water flow rate: 1.0 $\div$ 2.0 m <sup>3</sup> /h Pressure: 3.5 bar - 5 bar	Power: $\geq$ 40 kW Water flow rate: 1.0 $\div$ 2.0 m <sup>3</sup> /h Pressure: 3.5 bar - 5 bar
<b>OPERATING MODE</b>		Continuous operation					
<b>CONTROL MODE</b>		Automatic (controlled by a CEIA control and monitoring unit)					
<b>CONTROL AND MONITORING</b>		Automatically stabilized heating power (not influenced by power supply voltage variations)					
<b>SELF-DIAGNOSTICS</b>	Visual and acoustic fault signal	Monitoring of cooling water temperature and flow / Monitoring for short-circuits in the heating conductor / Internal fault / Monitoring of inductor dimensioning / Monitoring of the heating head connection / Monitoring of the power supply voltage value					
<b>OPERATING CONDITIONS</b>	Operating temperature	+ 5°C to + 55°C					
	Storage temperature	- 20°C to + 70°C					
	Relative humidity	0 - 95% (non condensing)					
<b>IP PROTECTION DEGREE</b>		IP54					
<b>WEIGHT</b>		132 kg	159 kg	270 kg	300 kg	500 kg	600 kg
<b>SAFETY FEATURES</b>		Complies with applicable international standards for Electrical Safety (EN 60204-1) and Electromagnetic Compatibility (EN 61000-6-2, EN 61000-6-4)					
		Galvanic isolation from the mains supply voltage					

# Generators

## Dimensions (mm)



### 25-SA/80 & 50-SA/80

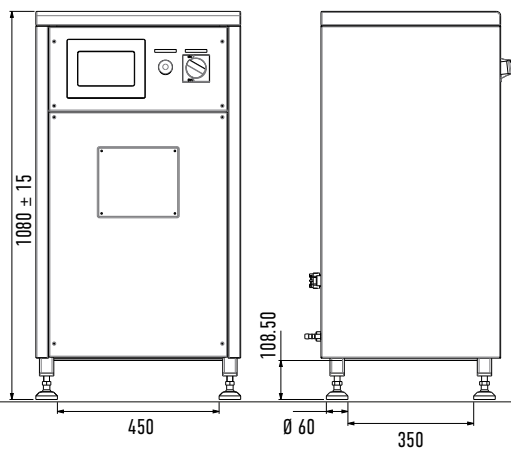

### 75-SA/80 & 100-SA/80

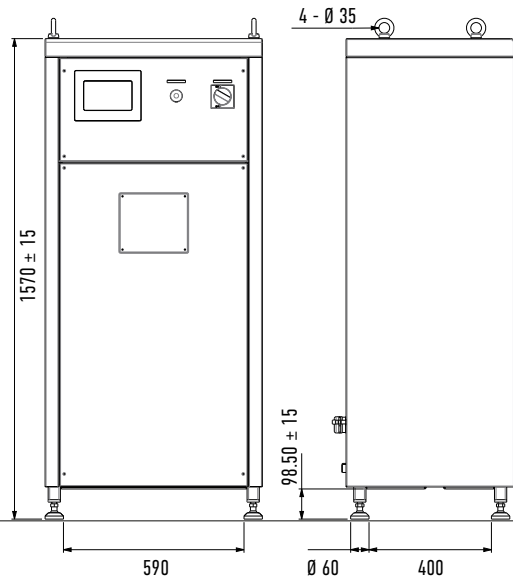

### 150-SA/80 & 200-SA/80

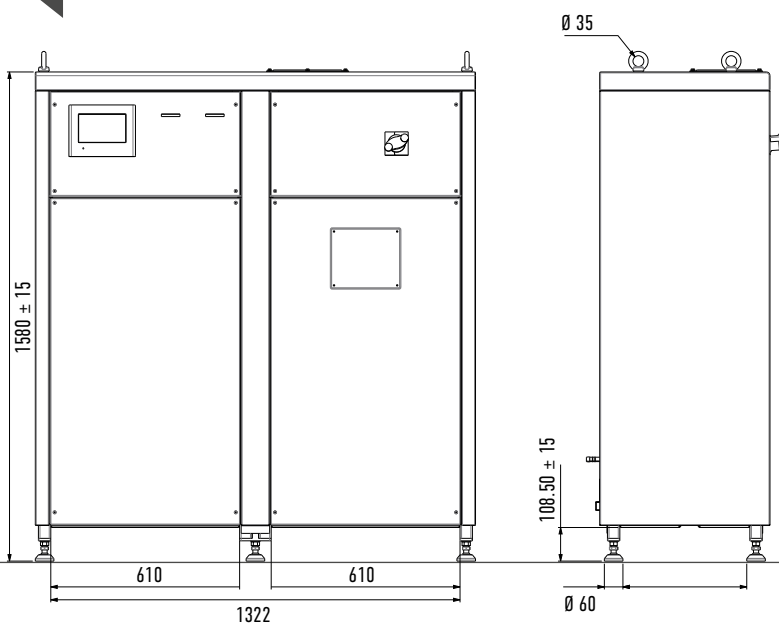

# Heating Heads Specifications



HEATING HEAD*		Dimensions [W x L x H]	Weight [Kg]	IP Protection Degree
PWH-1250		120 mm x 285 mm x 200 mm	15	IP54 (IP55 upon request)
PWH-2500		206 mm x 328 mm x 256 mm	24	IP54 (IP55 upon request)
PWH-5000		336 mm x 328 mm x 266 mm	34	IP54 (IP55 upon request)
PWH-7500		430 mm x 360 mm x 340 mm	40	
PWH-10000		330 mm x 383 mm x 400 mm	50	

\* Inductors shown in the pictures as example only

TYPICAL APPLICATION	GENERATOR				
	25-SA/80	50-SA/80	75-SA/80	100-SA/80	150-SA/80
MAGNETIC METALS i.e. Carbon Steel C40, C45, AISI 420, Nickel		PWH-1250		PWH-2500	PWH-5000
NON MAGNETIC METALS AND GRAPHITE i.e. Stainless Steel, Aluminum, Brass, Copper		PWH-2500		PWH-5000	

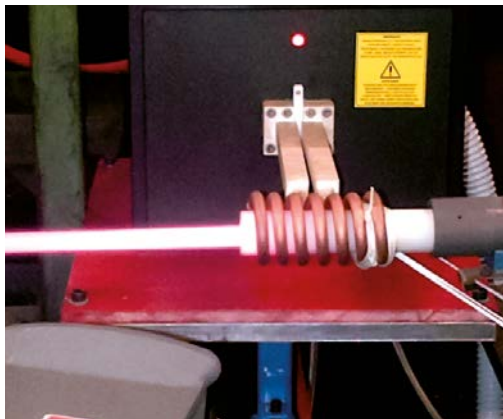
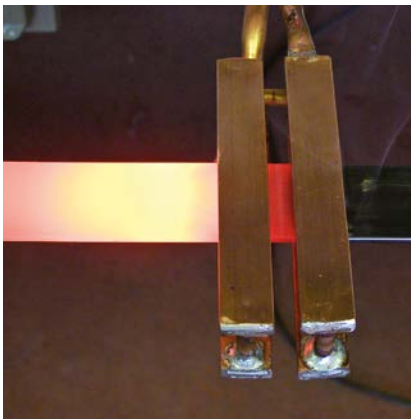

# Heating Heads

## Dimensions (mm)



**PWH-1250**

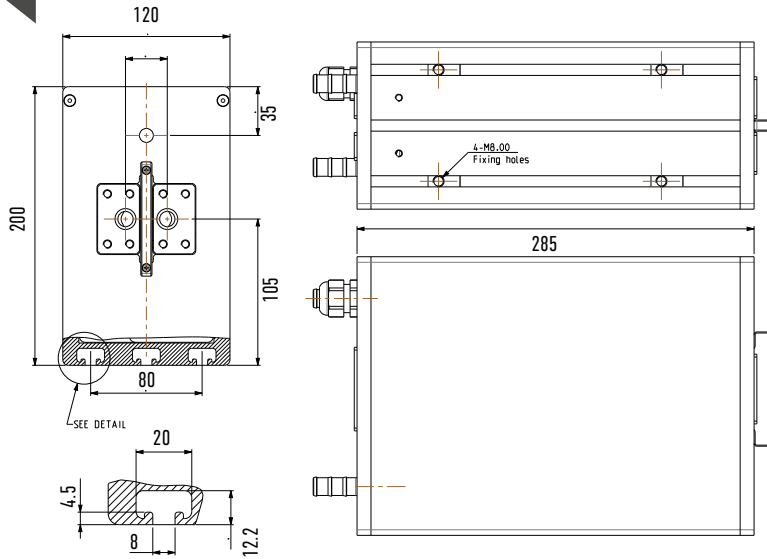

**PWH-2500**

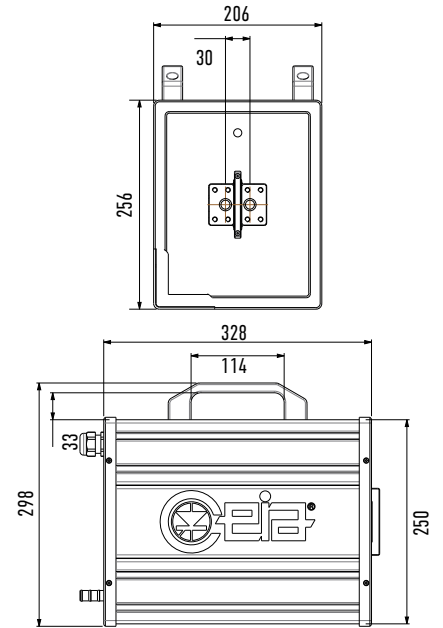

**PWH-5000**

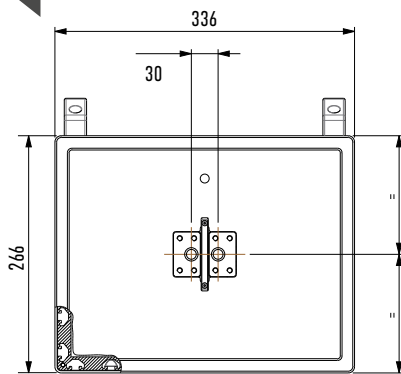

**PWH-7500**

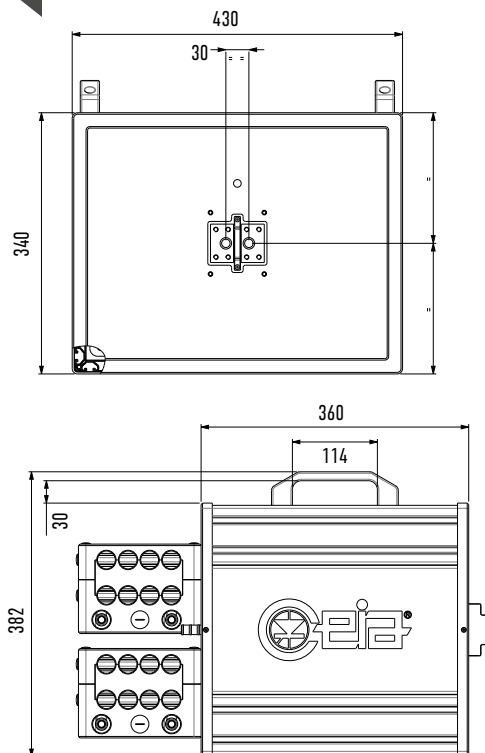

**PWH-10000**

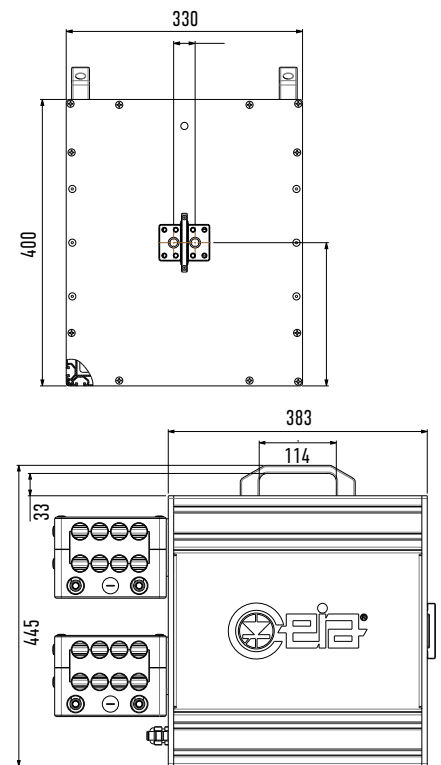



# SH/SLE Compact Optical Pyrometers

CEIA offers a wide range of infrared optical sensors, equipped with low-intensity LED aiming, which **covers an operating temperature range from 80°C to 2200°C**

## Features

- Adjustable emissivity from 0.1 to 1 [SH15/SLE series]
- High Accuracy
- High-Speed
- Very Compact design
- Temperature measurement independent from metal emissivity [SH2C/SLE series]
- Available with different focus distance and aiming spot size
- LED aiming light
- Supplied with Calibration Report traceable to Certified International Standards
- AISI 304 Stainless Steel Construction



SH15/SLE-550-D1 SH15/SLE-550-D2 SH15/SLE-550-D3 SH15/SLE-550-D4 SH2C/SLE

	SH15/SLE		SH2C/SLE	
			Single-color mode	Dual-color mode
TEMPERATURE RANGE	80... 2000°C		300... 2200°C	600... 2200°C
TEMPERATURE RESOLUTION	0.1 °C (up to 999.9 °C) 1 °C (above 1000 °C)		0.1 °C (up to 999.9 °C) 1 °C (above 1000 °C)	0.1 °C (up to 999.9 °C) 1 °C (above 1000 °C)
EMISSIVITY RANGE	0.1-1.0		0.1-1.0	N/A
RESPONSE TIME	100 µs Time Constant			
UNCERTAINTY	± 0.3% of reading in °C. All Pyrometers are supplied with calibration report traceable to certified International Standards			
MEASUREMENT SPOT AIMING	High Definition, 620 nm wavelength led beam			
INTERNAL DIGITAL CONTROLS	Offset and Range Calibration Parameters Environmental Temperature Measurement and Correction Automatic Gain Range Selection			
POWER SUPPLY	+/-15 V - +10/-5 mA, directly supplied by CEIA Controllers			
CONNECTION CABLE	Diameter 4.8 mm x Length 1.5 ... 4 ... 6 ... 9 m			
HOUSING	AISI 304 Stainless Steel			
WEIGHT	100 g			
PROTECTION CLASS	IP54 (IP65 upon request)			
OPERATING TEMPERATURE	0 °C to + 65 °C			
STORAGE TEMPERATURE	- 25 °C to + 70 °C			
CONFORMITY	Complies with applicable international standards for Electrical Safety and Electromagnetic Compatibility (EMC)			

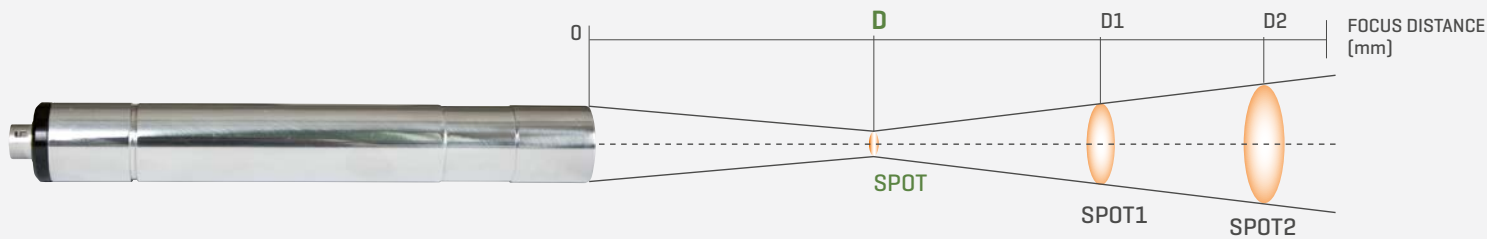

### Model Configuration and Optics Data

MODEL	Close-up lens	D distance [mm]	Spot diameter [mm]	D1 distance 1 [mm]	Spot 1 diameter [mm]	D2 distance 2 [mm]	Spot 2 diameter [mm]
SH15/SLE-550-D1 80... 700°C  (100° to 700°C with emissivity ≤ 0.5)	none	550	12.5	1000	36	2000	86
	CL240/SH15	240	4.5	500	24	1000	63
	CL120/SH15	120	2.5	250	19	500	52
	CL60/SH15	60	0.5	150	18.5	300	51
SH15/SLE-550-D2 120... 900°C	none	550	4.5	1000	21	2000	57
	CL240/SH15	240	1.5	500	18	1000	51
	CL120/SH15	120	1	250	17	500	46
	CL60/SH15	60	<0.4	150	19	300	50
SH15/SLE-550-D3 200... 1600°C	none	550	2	1000	16.5	2000	47
	CL240/SH15	240	0.6	500	16	1000	47
	CL120/SH15	120	<0.4	250	15	500	44
SH15/SLE-550-D4 500... 2000°C	none	550	2	1000	16.5	2000	47
	CL240/SH15	240	0.6	500	16	1000	47
	CL120/SH15	120	<0.4	250	15	500	44
SH2C/SLE 300... 2200°C	none	550	12.5	1000	36	2000	86
SH2C/SLE-240 300... 2200°C	none	240	4.5	500	24	1000	63

### SH15/SLE: Applications

- ANNEALING
- BONDING
- BRAZING
- CAP SEALING
- CURING
- FORGING
- HARDENING
- HOT FORMING
- LOCALIZED HEATING
- MELTING
- METAL GLASS SEALING
- NORMALIZING
- PREHEATING
- SINTERING
- SHRINK FITTING
- TEMPERING
- TIN SOLDERING

### SH2C/SLE: Applications

- HARDENING, FORGING, BRAZING, SOLDERING
- NOBLE METALS MELTING AND PURIFYING
- WIRE/ROD MILL
- SILICON PROCESSING
- GLASS INDUSTRY - GOB TEMPERATURE MEASUREMENT
- CEMENT INDUSTRY - CLINKER TEMPERATURE IN ROTARY KILNS

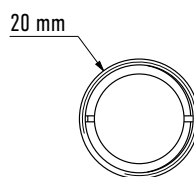
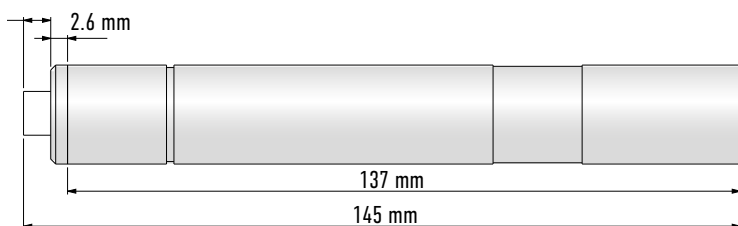



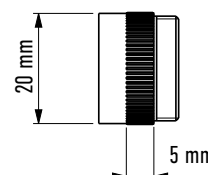



#### ▶ ADDITIONAL LENS



The SH/SLE sensors allow high quality management of the heating process according to the set temperature values. The reduced overall dimensions allow an easy integration of the pyrometer in automatic production systems.

Up to two optical sensors for temperature measurement can be connected to the generator.

ACCESSORIES	DESCRIPTION	FOCUS DISTANCE	CODE
	CLOSE-UP LENS SH15-FOCUS	240 mm	CL240/SH15
		120 mm	CL120/SH15
		60 mm	CL60/SH15
	COOLING JACKET UNIT WITH INTEGRATED AIR PURGE		SLE-PURGE-COOL
	90° VIEW MIRROR SYSTEM		SLE-90D-BD
	AIR PURGE UNIT		SLE-PURGE
	CONNECTION CABLE	SH15/SLE	Length: 1.5 m 49438
			Length: 4 m 49439
	SH2C/SLE	Length: 1.5 m 63272	
		Length: 4 m 63273	
	ES3M MICROMETRIC OPTICAL SENSOR BASE		23497
	SH23 OPTICAL SENSOR BASE		21871



CEIA HEADQUARTERS (ITALY)

# The CEIA Difference

► Constant market share growth thanks to the recognized outstanding quality and reliability of the installed equipment

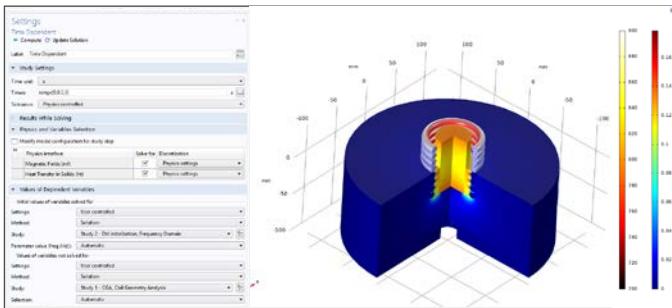

► Consolidated electromagnetic coil design and engineering capability



► ISO 17025 accreditation on Electromagnetic Testing



► Complete control and execution of the electronics manufacturing

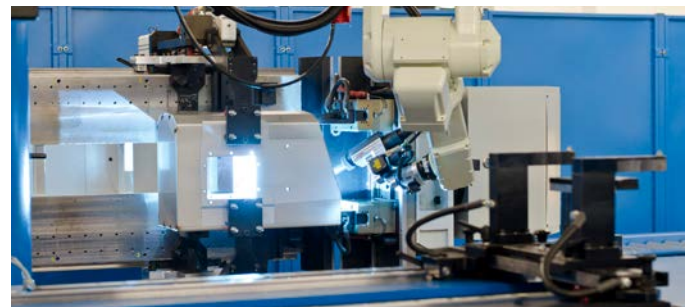

► Highly automated and repeatable mechanical manufacturing processes



► Digital Factory Testing, accurate automated calibration and final individual certification of the delivered equipment



CEIA - Zona Ind.le 54, 52041 Viciomaggio - Arezzo (ITALY)

T +39 0575-4181 • F +39 0575-418287 • E powercube@ceia-spa.com

www.ceia.net

CEIA reserves the right to make changes, at any moment and without notice, to the models (including programming), their accessories and options, to the prices and conditions of sale. DP040K0013v7000hUK-67301 (2021)

